

Q-Frame

Description:

An industry first from Melba Swintex, an all plastic Quick Fit Frame. Implementing the revolutionary Quick-Lock fasteners that are fitted as standard. These remain securely in place allowing a quick and easy sign face installation. The frame takes 300mm and 450mm centre sign plates. Black as standard with Corporate Branding and various all-through colour options available*.

Features:

- Takes 300 mm and 450 mm centre sign faces.
- Revolutionary Nylon Quick-Lock fasteners.
- Lighter than steel = less weight in vehicle.
- Non-Metallic with no scrap value.
- Non-Conductive.
- 100% recyclable.
- Stackable - 80 to a pallet.
- Can be branded with customer logo.*
- Can be manufactured in corporate colours.*
- 25mm Secure Webbing prevents leg over splay.

Standards:

- Conforms to requirements of **BS 8442:2015**
- Chapter 8 - The Traffic Signs Manual
- The Red Book 2013
- Traffic Signs Regulations & General Directions

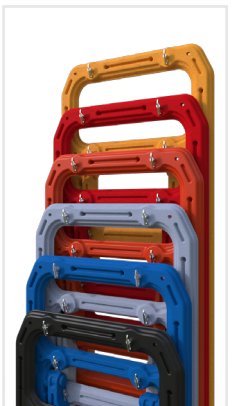
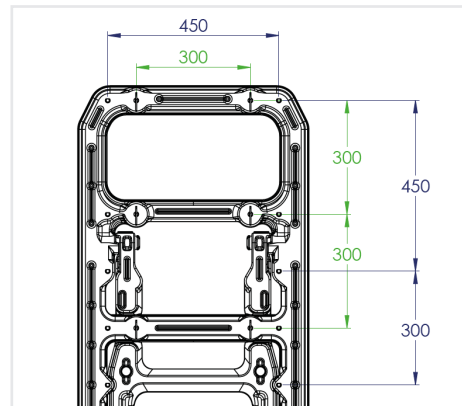

Height:	1505 mm
Installation Height:	1400 mm
Width:	605 mm
Depth:	65 mm
Weight:	5 kg

*Min. Order Quantity Applies
*All weights are approximate

The information given on these sheets is typical of the product depicted it must not be interpreted as a guarantee of individual product performance and/or characteristics. We reserve the right to alter specifications and designs without prior notice. All measurements are in millimetres (mm)



FM 673547